

User's Guide

for Super Prism Projector



ARTOGRAPH®

2838 Vicksburg Lane North, Plymouth, MN 55447 USA
Tel: 888-975-9555 E-mail: info@artograph.com
www.artograph.com

SETUP & OPERATION

Step 1

CONTENTS:

Projector + Prism lens
+ Super Prism lens

1 LENS INSTALLATION:

The Super lens comes installed into the projector and should be used for all enlargement needs. To achieve reduction, install the included Prism lens as indicated. The rubber "O" ring (#3) should be rolled down to the end of the lens that is sticking out of the projector. This ring prevents the lens from entering too far into the lens travel.

2 PROJECTION AREA

All opaque projectors work like a flashlight; the darker the room, the brighter the projected image will appear. The clearest and brightest images are produced in a completely dark room. For best results, operate your Super Prism in a room where you are able to control the lighting conditions or work in the evening. To achieve the maximum image size of approximately 20X, a minimum distance of 18 ft. (5.5m), measured from the label above the lens to the projection surface, is required (see Distance Chart for further information).

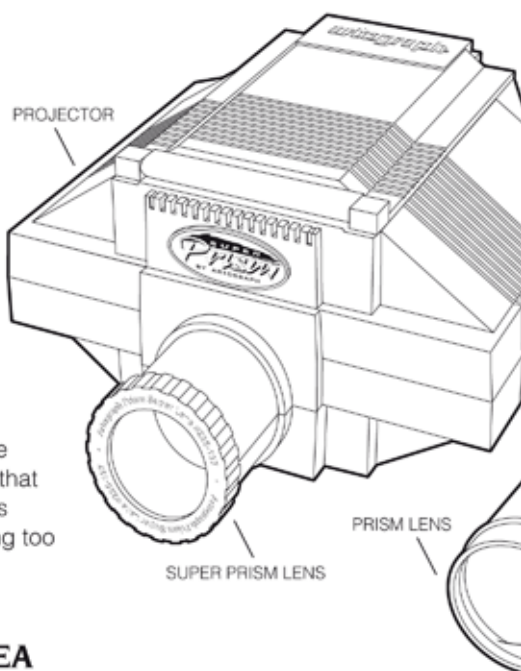

Mount the projector onto a surface that can be easily moved. Movement of the projector is required to achieve the desired size. A taboret or rolling cart is ideal. Artograph offers an optional Projector Floor Stand, item #225-350, that can be easily moved and raised for the ultimate in image positioning.

3 PROJECTING

To load the projector, simply lift the copy board lid of the projector and mount your copy face down onto the glass surface. The metal copy clip may be pushed to the side if desired as it is only necessary when mounting the projector onto the accessory Prism Table Stand, item #225-206. Close the cover, plug the projector into an outlet and turn the projector on by flipping the switch at the back of the unit. Turn the room lights off. You are now ready to adjust the size and clarity of the projected image. Always adjust the desired size of the projected image first before focusing it. (See Distance Chart for approximate distance.)

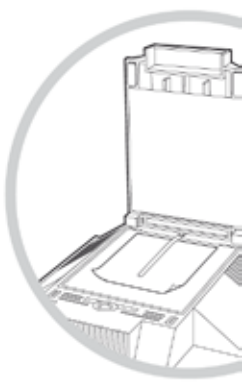
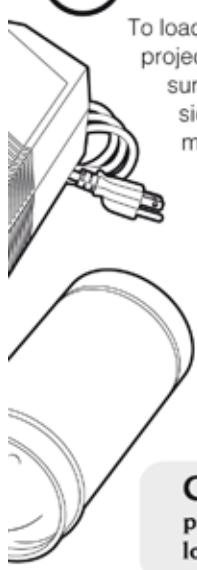

Caution: During operation, ensure the projector is properly ventilated. Do not block the exhaust or inlet vents located on the back and sides of the projector.

4 GENERAL FOCUSING & ENLARGING

The size and clarity of your projected image is determined by the distance of the projector from the projection surface and the focusing of the lens. The farther the projector is from the work surface, the larger your image will be. As you change distance, you will have to slide the lens in or out slowly within the lens barrel to focus the projected image.

5 COPY AREA

The copy area is 7" x 7". This indicates the maximum size of copy the lens can see. This copy size, however, varies with the desired projection size. With greater enlargement, the lens sees less of the copy area.

6 PHOTOGRAPH PROJECTION (USE CAUTION!)

Photographs are commonly used in projectors; however, a few precautions must be taken:

1. **Work from a copy of any valuable or important photographs.** Never use an original if it cannot be replaced. Photographs were not intended to handle the intense light and heat created by a projector. Though this projector is fan-cooled and ventilated to keep the copy cooler, it does get hot and photographs may be adversely affected by the heat and light.
2. **Never project old photographs** as they are particularly sensitive to heat and light and they will be damaged. Again, have a copy made.
3. **To prevent photographs from curling, mount them to a stiff backing material or put them in a picture mat.**
4. **When projecting, make sure that the fan is operating and that the cooling vents have not been obstructed.** When finished tracing the projected photo, turn the projector off and remove photo.

(OVER PLEASE)

TIPS & TECHNIQUES

Oversized Copy/Books

Step 2

If your original is larger than what will fit onto the copy area, or if you are working from a picture in a book, simply remove the lid from the projector by pulling up the cover carefully and removing the two pivot pins. Place the copy or book on top of the projector. The lens will still only see a 7" x 7" portion of this copy, but placing it on top will allow you to move it around and project it in sections. Once you have drawn a section, move the copy and realign the projected image to the stopping point of the traced area. Resume tracing and repeat as many times as necessary. The other alternative to oversized copy is to reduce the original on a copier, so that it fits within the 7" x 7" copy area.

Another way to make use of oversized copy that is not manageable on top of the projector is to place the copy face-up on your tabletop, remove the projector lid and place the projector upside down and on top of the copy. This way the copy will remain rigid and your projected image is more likely to line up properly.

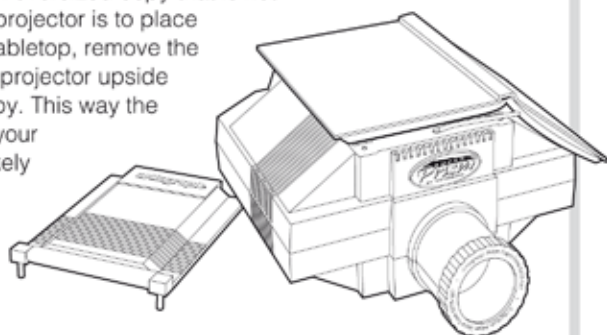

Small 3-D Objects

Small 3-D objects can be projected by removing the projector lid and placing the object on top of the projector copy area. To ensure maximum image clarity, place a box over the top of the object to eliminate ambient light (light escaping from the top of the projector). To project 3-D objects which are larger than the 7" x 7" copy area, take a photograph of the object and project the print.

CAUTION: Do not mount aerosol cans or pressurized objects onto the projector. The hot surface may cause them to burst.

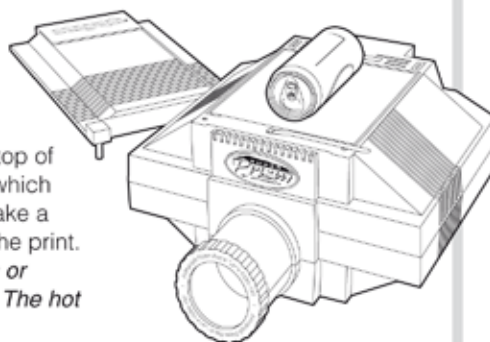

Measurements of Projections

To determine a particular scale of a projected image, mount a 6" ruler next to the copy or draw 1" grid lines onto the copyboard itself. If specific enlargements are frequently used from common originals, mark the floor with tape. Position the tape at desired distances and mark the image size directly on the tape for future reference (i.e. 10x). Then simply align the cart, Projector Floor Stand (see Accessories Section of this manual), or table with the tape mark to attain that size.

Minimizing Distortion

Distortion is largely created when the projector is not projecting squarely (perpendicular) onto the desired surface. Imagine shining a flashlight onto a wall. If the flashlight is shining straight ahead, the light is a round circle. If the flashlight is turned to an angle, either up or down or back and forth, the circle of light is distorted. This same concept applies with a projector. To minimize distortion, always keep the projector level and the image square to the wall, canvas or other vertical surface.

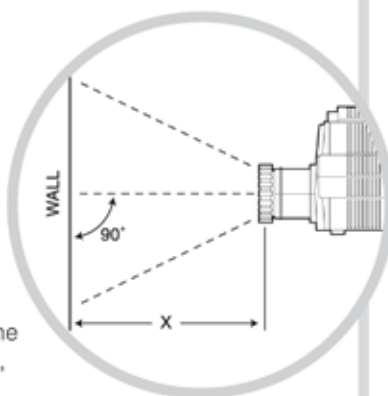

Common Uses for Projectors

Art projection has been used in fine art painting since the Renaissance. The earliest form of the camera obscura pinhole viewing system, used to project and visualize images, dates back to the 1500s. Artograph brings the benefits of 21st century technology and precision engineering to the tradition of art projection, and provides today's artists, crafters and designers with an indispensable tool of the trade.

Your Super Prism has an almost endless array of uses...

Brush Up Your Drawing Skills

Trace around images to improve hand and eye coordination, understand perspective and learn to draw better.

Step 3

Paint on a Grander Scale

Free up your creative skills and gain confidence to work on larger paintings and murals.

Repeat Success

Transfer an accurate repeat image for cartooning or decorating walls, furniture, fabrics, pottery, cake icing – in fact, just about any surface to be hand-painted.

Save Time

Produce paintings and decorative work faster – for fun and profit!

Murals

Artists, crafters and designers can use the Super Prism to create inviting or whimsical wall murals and larger paintings for children's rooms, hallways, doors, living rooms, office spaces and more. Project favorite sports figures, animals or themes from magazines or books directly onto the wall, trace and color as desired.



Education/Classroom Work

Teachers will discover a variety of uses for their Super Prism while enlarging maps, animals or constellations for students to view or trace. School posters, banners and props for plays and productions are made quickly and easily with a projector.



Signs

Anyone can create banners and signs with ease with their Super Prism. Project lettering from a book or fonts printed from a computer to design store signs, party banners etc.



Woodworking

Carvers can quickly transfer their patterns, designs, sketches and even photos directly onto wood pieces. As little or as much detail as desired can be transferred to any wood surface to make carvings more precise and accurate.



Fabric Design

Quilters, silk painters, stencilers and many other types of designers and crafters who work with fabric can use their Super Prism to project and manipulate the size of their patterns and designs. Choose a favorite fabric design and incorporate it into your quilt or fabric.

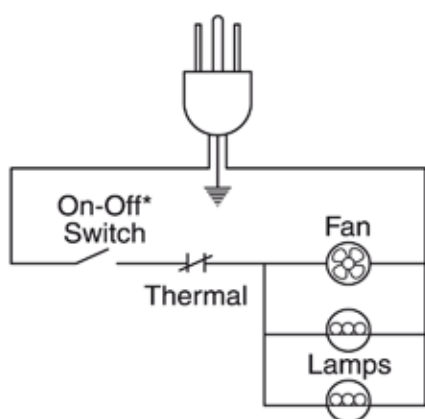

Step 5

PROJECTOR MAINTENANCE

Lens

Clean the lens with any lens cleaner and soft cloth or lens tissue. Apply cleaner to the cloth – NEVER apply cleaner directly onto the lens, as it may seep inside.

Step 6

Mirror/Lamps

To clean mirror or replace lamps, first disconnect power supply.

Loosen plastic screw near the back of the projector next to the top glass with a coin or screwdriver. Remove top glass and set aside.

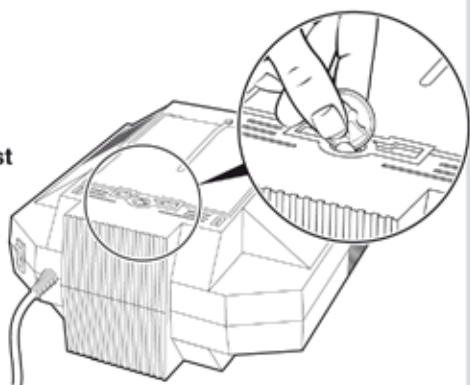

MIRROR

The Super Prism has a special front-surface mirror which eliminates double imaging and enhances brightness. Clean its silvered surface with care, using a mild cleansing solution and a soft cloth or tissue. DO NOT scrub.

LAMPS

The Super Prism uses two each of a 250-watt ECA photo lamp. Replacement lamps can be ordered from an Artograph dealer, direct from our factory, or from your local bulb supplier or camera supply store. To order direct from Artograph, contact us toll-free at 1-888-975-9555, mail the enclosed parts order form or visit us online at www.artograph.com.

WARNING: Never use lamps that exceed 250-watts. (275 watt lamps may be used in U.K. & Australia.)

ACCESSORIES

Prism Table Stand (#225-206)

Designed to be used with both the Prism and the Super Prism projectors, the Prism Table Stand attaches easily and securely to the projector and onto any table edge to allow for convenient tabletop projection. Projection range with this stand is from 80% (4/5x) reduction up to 3x enlargement. Swivels to the floor for increased enlargement range.

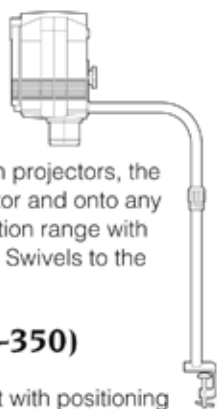

Projector Floor Stand (#225-350)

Adjustable sturdy stand designed to assist with positioning of the projected image. The stand incorporates a large adjustable platform that will allow for quick and easy positioning of your projector onto a wall, easel, or other vertical surfaces. The platform may be rotated 360 degrees, tilted 15 degrees front to back and elevated up from 3 ft. to 4½ ft. high.



OTHER ARTOGRAPH PRODUCTS

Spray Booths

Artograph manufactures a full-line of Spray Booths which reduce the mess and hazards associated with sprayed materials like paints, fixatives and adhesives by effectively trapping and filtering the overspray and fumes.

Light Boxes

Artograph manufactures a full-line of light boxes of varying sizes that feature a conveniently slanted work surface and handy recessed tool tray. Ideal for backlighting designs, patterns and stencils for embossing, sewing, quilting, scrapbooking, custom cards, cartooning, lettering and many other tracing and viewing applications.

USE IT TO...

Size Up

The fast, easy way to enlarge and project photographs, prints, patterns, designs and sketches onto almost any surface.

Find the Best Composition

Arrange the elements of a painting to decide on the best composition and see how an additional feature would look in the picture before it's committed to the surface.

Define Features

Enhance and define features and tonal range in portrait painting when working from a photograph or sketch.

APPLICATIONS

Fine Art

Fine Artists of all varieties using many types of media will find the Super Prism invaluable. Photographs, thumbnail sketches, artwork and designs can all be scaled and reproduced in the size needed to accomplish portraits, landscapes, still life and many other fine art formats.



Decorative Painting

Artists and crafters who decorate on wood, metal pieces or ceramics will find the Super Prism ideal for visualizing placement of their pattern or stencil, whether it be on wood plaques, furniture, dishes, Shaker boxes or just about any surface to be decorated.



Airbrushing

Artists that airbrush onto fabric or any other media will find the Super Prism useful in gaining an outline and position for their image. Project the image, trace the outline and airbrush the color in.



Illustration

Illustrators will find the Super Prism to be indispensable in scaling up their thumbnail sketches, logos and small 3-D objects.



Home Décor

Designers and crafters can work with repeats, patterns and stencils from wallpaper and fabric to transfer onto walls, furniture, canvas or ceramic and pottery pieces for endless decorating possibilities.



ELECTRICAL SCHEMATIC

Super Prism 120v AC 60 Hz, 4.7 amps

- 220/240 Volt AC 50 Hz units are wired so that both incoming leads may be shut off at the switch.

The Super Prism includes two lenses; the Super Lens (installed in the projector) and the Prism Lens. The Super Lens is a precision 3-element color-corrected lens which provides an enlargement range from 200% (2x) up to 2000% (20x). The additional Prism Lens is designed to provide image reduction to 80% (4/5x). Please Note: A gap exists in the projection range that cannot be achieved due to the reversing of the lens -170% to 250%. You will have to adjust the size of your original to achieve a size in this range.

Super Lens Distance Chart (approximate) – Measured from label above lens to projection surface.

| Range | 2X | 5x | 10x | 20x |
|----------|----------|--------|--------|-------|
| Distance | 32" | 57" | 8.6' | 16.5' |
| | (81.3cm) | (1.4m) | (2.6m) | (5m) |

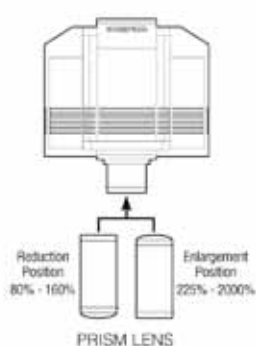

Prism Lens Distance Chart (approximate) – Measured from label above lens to projection surface.

| Range | .8 | 1x | 5x | 10x | 20x |
|----------|--------|--------|--------|--------|--------|
| Distance | 24" | 23" | 47" | 89" | 14' |
| | (61cm) | (58cm) | (1.2m) | (2.3m) | (4.3m) |

[Lens in reduction position] [Lens in enlargement position]

WARRANTY

Be sure to fill out and mail the enclosed warranty registration card. You may also register your Super Prism online at www.artograph.com.

Artograph projectors are guaranteed against all defects in material and workmanship for five years from the date of sale to the original purchaser. Any part of the equipment which becomes defective under normal installation and use will be repaired or replaced without charge for factory labor and materials, providing the equipment is returned, shipping pre-paid, to our factory within this period. CONTACT OUR OFFICE FOR RETURN AUTHORIZATION. This warranty does not apply to all lamps or equipment which has been subjected to abuse, accident, or alteration, nor to equipment which has been improperly installed or wired in violation of the printed instructions furnished. The warranty registration card should be filled out and returned immediately to ensure warranty service. You may also register your Artograph product online at www.artograph.com.

PARTS LIST:

- | | |
|--|------------------------------------|
| 1. Super Lens225-197 | 7. Lamps, Two 250-watt ... 106-043 |
| 2. Prism Lens200-728 | 8. Lid/Cover 151-523 |
| 3. Retaining O-ring 151-571 (Prism Lens only) | 9. Copy Clip 151-570 |
| 4. Power Switch 145-306 | 10. Top Glass 108-045 |
| 5. Power Cord 145-347 | 11. Right Lid Pivot 151-565 |
| 6. Mirror 108-023 | 12. Left Lid Pivot 151-564 |

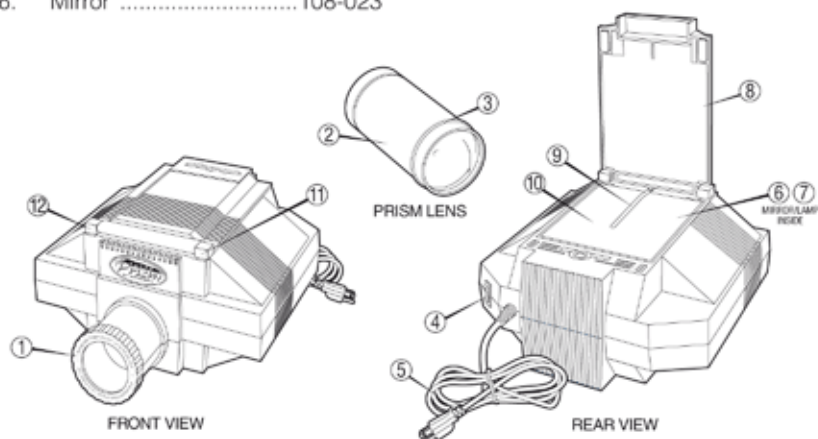

IMPORTANT SAFEGUARDS

When using this projector, always follow basic safety precautions, including the following:

1. Read and understand all instructions before operating.
2. Close supervision is necessary when used by or near children. Do not leave unattended while in use.
3. Do not operate this equipment with a damaged cord, or if it has been dropped or otherwise damaged, until it has been examined by a qualified electrician.
4. If an extension cord is necessary, be sure it has a suitable current rating. Cords rated for less amperage than this equipment may overheat. Be careful to arrange the cord so that it will not be tripped over or pulled.
5. Always unplug from the electrical outlet when not in use or when replacing lamps. Disconnect by grasping and pulling the plug from the outlet; never yank the cord to disconnect the plug.
6. Allow the projector to cool completely before moving. Loop the cord loosely when storing.
7. If the projector receives water damage, do not use until inspected by a qualified electrician.
8. To avoid electrical shock hazard, do not disassemble. Take the projector to a qualified electrician. Incorrect reassembly can cause an electrical shock hazard.

PLEASE SAVE THESE INSTRUCTIONS